

PaperPulse: An Integrated Approach for Embedding Electronics in Paper Designs

Raf Ramakers Kashyap Todi Kris Luyten

Hasselt University – tUL – iMinds, Expertise Centre for Digital Media, Diepenbeek, Belgium

Abstract

We present PaperPulse, a design and fabrication approach that enables designers without a technical background to produce standalone interactive paper artifacts by augmenting them with electronics. With PaperPulse designers overlay pre-designed visual elements with interactive widgets and specify functional relations between them using a logic demonstration and recording approach, called Pulsation. When the design is finished, PaperPulse generates layered electronic circuit designs, code that can be deployed on a microcontroller, and instructions for assembly.

1 Introduction

Augmenting paper with electronics makes it possible to bring liveness to printed graphics, from books, posters and business cards to ephemeral packaging material and flyers. Although advancements in fabrication tools for electronic circuits, such as conductive pens, threads, inkjet printers [Kawahara et al.] and vinyl cutters [Savange et al.] make it accessible for many people to build these paper circuits, a vast majority lacks expertise in electronics and programming to make paper interactive using electronic circuits. PaperPulse [Ramakers et al.] overcomes these challenges by contributing:

1. A design tool to integrate electronics in paper, and specify, test, and debug logic between these components. When fabricating, the tool assists by automatically generating circuits, microcontroller code, and assembly instructions.
2. Pulsation, a demonstration technique to enable non-programmers to specify logic between electronic sensors.
3. Three families of interactive widgets, suitable for paper. Each family consists of standard controls, such as push buttons, switches, sliders and radio buttons.

2 Workflow

Figure 1 illustrates the process of designing and fabricating a paper game in which a loop of six LEDs consecutively turn on and off. When the player “grabs the banana”, by pressing a button at the moment when a particular LED lights up, the game is completed and a buzzer rings. (a) The designer overlays imported pre-designed images with interactive components, available in the widget toolbox. He then links the “stop-go” switch to the circle of the LEDs by demonstrating and recording the input/output actions and parameters as shown in Figure 2-a. Similarly, the logic for the “grab now” button is specified (Figure 2-b). After verifying the recorded rules in the simulator, PaperPulse generates a layered electronic circuit design, microcontroller code, and assembly instructions. (b) The designer prints the circuit using a conductive printer and assembles the circuit by attaching electronic components. (c-d) After uploading the generated code to the microcontroller, the artifact can be used as a standalone game on paper.

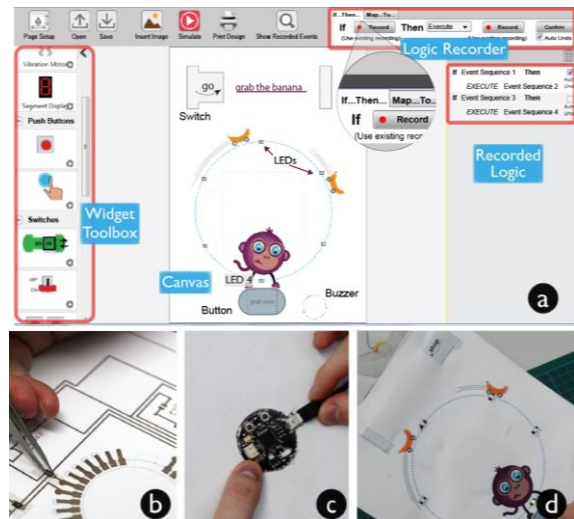

Figure 1: (a) Design and specify logic (b) Printing and assembly; (c) Upload generated code; (d) Final result.

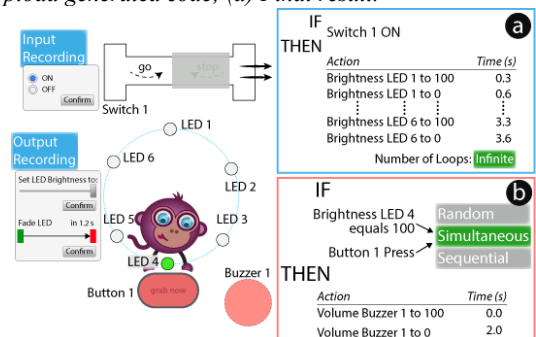

Figure 2: Recording and demonstrating logic using Pulsation.

3 Pulsation

Pulsation allows users to specify logic by demonstrating and recording actions directly in the context of the visual design elements. To provide a higher ceiling than is possible with demonstration alone, Pulsation augments widgets and the demonstrated actions with dialogs that allow fine-tuning specific properties as shown in Figure 2.

Pulsation allows for specifying relations between conditions and output actions in two ways: (1) if-then rules execute output actions when a set of conditions have been satisfied. (2) map-to rules link a parameter of the input (e.g. raw value, repetitions, progress through a set of actions) to the output (e.g. value, number of executed output actions, speed with which the actions are executed).

References

- KAWAHARA, Y., et al. Instant inkjet circuits: Lab-based inkjet printing to support rapid prototyping of ubicomp devices. In Proc. UbiComp '13, 363-372.
- RAMAKERS, R., et al. PaperPulse: An Integrated Approach for Embedding Electronics in Paper Designs. In Proc. CHI '14.
- SAVANGE, V., et al. Midas: Fabricating custom capacitive touch sensors to prototype interactive objects. In Proc. UIST '12.