

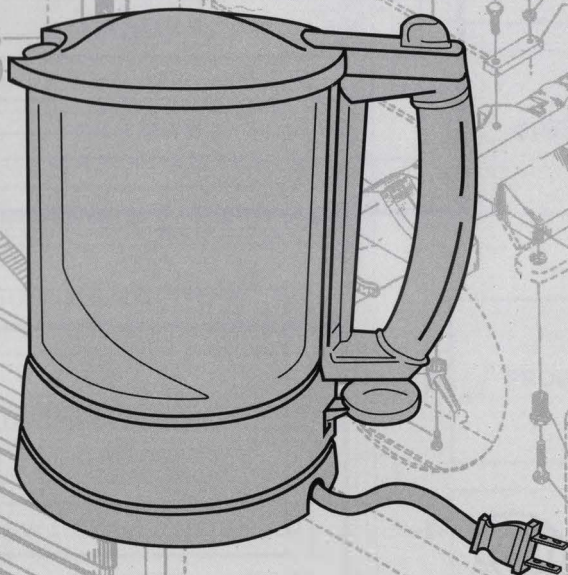

SIGGRAPH 2003
SAN DIEGO

ANIMATION THEATER PROGRAM PART 1

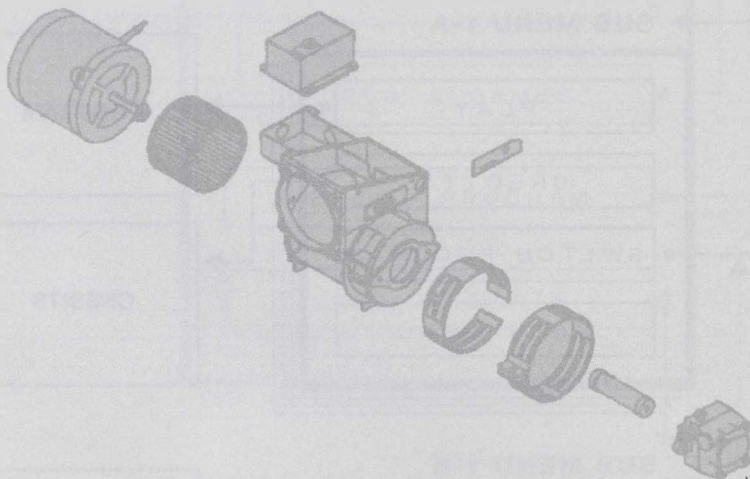



Order Information:

SIGGRAPH Video Review
c/o ACM
PO BOX 11414
New York, NY 10286-1414
USA

phone: +1.800.342.6626 USA/Canada
+1.212.626.0500 International
fax: +1.212.944.1318
email: svrorders@siggraph.org
www.siggraph.org/publications/video-review/SVR.html

Most of the pieces in this SIGGRAPH Video Review are copyrighted. Therefore, they are not to be duplicated, broadcast, photographed nor edited without the express written permission of the individual copyright holder.

IT TAKES CHARACTER

- 01 Carl & Ray Continued: Tippett Studio 3D Character Animation for Blockbuster
- Tippett Studio
 - 02 Bert - Academy of Art College
 - 03 Sprite "Kebab" - Glassworks
 - 04 Solder Man - Crash & Sues
 - 05 Pingwin - Wojtek Wawszczyk
 - 06 My Backyard - Vancouver Film School
 - 07 Sam - Kyle Winkelman / Savannah College of Art & Design
 - 08 El Arquero - Vancouver Film School
 - 09 On the Sunny Side of the Street - The Soulcage Department
 - 10 SpiderWeb - Rhythm & Hues Studios
 - 11 Ritterschlag - Filmakademie Baden-Wuerttemberg
 - 12 This Wonderful Life - Liam Kemp
-

FUN & GAMES

- 01 Baby Changing Station - Ringling School of Art and Design
- 02 Plumber - Red Rover Studios Ltd.
- 03 Shining Lore - NCsoft Corp.
- 04 TicToc - Filmakademie Baden-Wuerttemberg
- 05 "Yeah! The Movie" - NVIDIA and Spellcraft Studio GmbH
- 06 Cane-Toad - Andrew Silke
- 07 Traffik - Savannah College of Art & Design
- 08 WarCraft III: Reign of Chaos - Blizzard Entertainment

IT TAKES CHARACTER

01 Carl & Ray Continued:

Tippett Studio 3D Character Animation for Blockbuster

1:10

The continuing adventures of "Carl & Ray", those zany, furry Blockbuster Video characters created by the artists of Tippett Studio. In this year's montage, the Tippett team has further refined and built on the artistic and technical challenges of bringing photo-real house pets into the realm of the fantastic. Whether they be dancing, sliding, juggling, or dripping with water, Carl & Ray continue to entertain audiences worldwide while setting new standards for photo realistic fur and 3D character animation.

Director: Steve "Spaz" Williams

Producers: Carol Corwin, Alonzo Ruvalcaba, Clint Goldman, Paul Renusch, Josh Reynolds

Visual Effects Supervisors: Joel Friesch, Jim McVay, Scott Souter, Frank Petzold

Producers: Carol Corwin, Alonzo Ruvalcaba

Lead Animators: Todd Labonte, Eric Reynolds

Animators: Jim Brown, Raquel Coelho, David House, Patrick Lowery, Karen Prell, Morgan Ratsoy

Puppet: Tracey Roberts

Model: John Koester

Paint: Laura Hainke, Raine Reene, John McLaughlin

Technical Directors: Kirsten

Drummond, Tulio Hernandez,

Holly Kim, Jim Valladao,

Ben Von Zastrow

Compositors: Charles Granich,

Keith McGowan, Chris Morely,

Ben Von Zastrow

VFX Coordinator: Dan Riha

VFX Editors: John Bartle,

Jennifer Hutcheon

Software Development:

Todd Stinson

Contact:

Jim Bloom

Tippett Studio

2741 10th Street

Berkeley, CA 94710

USA

+1.510.649.9711

+1.510.649.9788 fax

jbloom@tippett.com

www.tippett.com

02 Bert

4:30

A tale of a young vegetable's search for family. "Bert" is Lee's first film and senior project at Academy of Art College, San Francisco.

Director/Producer: Moonsung Lee
Contributors: Trio Voronezh,
Jed Diffenderfer, Jimmy Hayward,
Oren Jacob, Dave Burgess,
Andrew Leung, Hyunjoo Jung

Contact:
Moonsung Lee
Academy of Art College
25 Rockledge Avenue #912
White Plains, NY 10601
USA
+1.914.948.7932
spiff73@hotmail.com
artist.cgland.com/spiff73

03 Sprite "Kebab"

00:30

A goblin in a kebab shop is brimming with innocent yet mischievous character. The facial expressions and delicate arm and finger movements bring the 'sprite' to life. The goblin was originally sculpted by hand and then made into a full latex puppet. The puppet was then laser scanned to provide 3D wireframes, Glassworks then applied high-resolution digital images of the original puppet to the wireframes to create the 3D model and give it texture.

Director: Kuntz / Maguire
Producer: Zoe Rogers

Contact:
Jay Lichtman
Glassworks
33/34 Great Pulteney Street
W1F 9NP London
United Kingdom
+44.207.4343.1182
jay@glassworks.co.uk

04 Solder Man

3:53

A story of creation, evolution and problem solving. After experiencing a problem with his creation, solder man looks to solve his dilemma the only way that he knows how, by soldering. With great effort he is successful, but finds himself in much worse shape. Then as luck or fate would have it, he stumbles across a substance that greatly expands his horizons. Life though is never without its problems, and in the end we are left wondering how much he has grown.

Director/Producer: Dave Novak
 CG: Dave Novak
 Compositing: Jake Parker
 Color Correction: Sue Lakso,
 Demetri Kitsopoulos
 Sound: Echo Boys
 Effects: Tom Lecher
 Music: Alex Berglund, Billy Franklin

Contact:
Dave Novak
Crash & Sues
510 Marquette Avenue
Suite 600
Minneapolis, MN 55402
USA
+1.612.338.7947
+1.612.338.4601 fax
dave@crash-sues.com

05 Pingwin

2:40

A short animated movie about a penguin who wants to fly.

Director: Wojtek Wawszczyk
 Producers: Wojtek Wawszczyk,
 Georg Gruber
 Contributors: Kamil Polak,
 Alan Shamsudin

Contact:
Wojtek Wawszczyk
Radomska 14/62
41-219 Sosnowiec
Poland
+48.6.0695.0987
wawszczyk@yahoo.com

06 My Backyard

1:03

A spider's journey.

Director: Chrisoph Ammann
 Producer: Vancouver Film School

Contact:
Sabrina de los Rios
Vancouver Film School
420 Homer Street
Vancouver, BC V6B 2V5
Canada
+1.604.685.6331 x109
+1.604.685.6317 fax
sabrina@vfs.com
www.vfs.com

07 Sam

5:29

In the distant future of a galaxy very dissimilar to our own, an otherworldly janitor named Sam begins his duties at the cargo distribution center of WGA-Minora Biocybernetics. In the midst of cleaning up debris and longing for a life other than his own, Sam is suddenly presented with an unsupervised cargo plane, a disk containing all the knowledge of a cargo pilot, and the opportunity for the misadventure of a lifetime.

Director: Kyle Winkelman
 Producer: Joe Pasquale
 Animation: Joshua Merck
 Lighting: Ginka Kostova
 Sound Design: Robin Beauchamp

Contact:
Kyle Winkelman
Savannah College of Art & Design
318 West Hall Street
Apartment B
Savannah, GA 31401
USA
+1.912.713.1541
superwinkel@hotmail.com

08 El Arquero

4:41

An archer's wild shot leads to a frantic chase with the constellation Leo.

Director: Raphael Perkins Producer:
 Vancouver Film School

Contact:
Sabrina de los Rios
Vancouver Film School
420 Homer Street
Vancouver, BC V6B 2V5
Canada
+1.604.685.6331 x109
+1.604.685.6317 fax
sabrina@vfs.com
www.vfs.com

09 On the Sunny Side of the Street

4:58

A Harlem street scene in the 1920's. H.H. Sablin just wants to read his daily newspaper, as his bench-neighbor Pit Doogey acts very busy preparing a barbecue, without taking any regard of Sablin. Under these conditions, the accidental meeting of both couldn't have a happy ending, could it?

Directors: Wilhelm Landt,
Joachim Bub
Producer: The Soulcase Department
Contributors: Wilhelm Landt,
Joachim Bub, Elmar Keweloh,
Mike Meyer

Contact:
Wilhelm Landt
The Soulcase Department
Mecklenburgerstrasse 10
28203 Bremen
Germany
+49.421.794.7020
willi@soulcase-department.de

10 SpiderWeb

1:00

For Rhythm & Hues, an animation house utilizing both proprietary and commercial software packages, the ability to freely exchange useful data between applications is essential. The options become quite liberating in a modular pipeline.

Director: Sei Nakashima
Producer: Stacy Burstin
Animation Director:
Christopher Romano
Producer: Stacy Burstin
Music Composer: Steve Kutay
Sound Designer: Michael Miller
Sound Effects Editors:
Michael D'Ambrosio, Tim DeLone

Contact:
Stacy Burstin
Rhythm & Hues Studios
5404 Jandy Place
Los Angeles, CA 90066
USA
+1.310.448.7500
stacy@rhythm.com
www.rhythm.com

11 Ritterschlag

7:00

Held in prison by dragons, the beautiful princess cries. This full CG short film was made by a small team in 13 months.

Director: Sven Martin
 Producer: Daniel Mann, Marco Gilles
 Animation: Sven Martin, Sebastian Frey
 Digital Environment: Sven Dreesbach, Volker Willmann
 Lighting: Oliver Finkelde
 Script: Marcus Sauermann
 Music: Marius Lange

Contact:
Katrin Arndt
Institut of Animation, Visual Effects and Digital Postproduction
Filmakademie Baden-Wuerttemberg
Mathildenstr. 20
71638 Ludwigsburg
Germany
+49.7141.969.800
+49.7141.969.888 fax
animationsinstitut@filmakademie.de
www.animationsinstitut.de

12 This Wonderful Life

2:00

A young woman mourning the death of her husband takes a walk into the countryside, feeling alone and withdrawn from life. Her sense of isolation is lifted when she discovers, beneath a bridge, an abandoned baby. As the woman and the baby begin to develop a natural bond, her perception of what it means to be alive changes forever.

Contact:
Liam Kemp
66 Spindletree Drive
Oakwood
DE21 2DG Derby
United Kingdom
+44.133.283.2251
liam@fourbarns.fsnet.co.uk

FUN & GAMES

01 Baby Changing Station

1:22

Seeking a moment's peace in a mall bathroom, an exasperated father places his screaming, dirty-diapered child on a baby changing station and tries to regain his composure. The baby's screams seem to grow louder and show no sign of stopping. And then, silence. He's afraid to look, but when he does, transformation of his attitude is not the only change that occurs in this tale of diapers and drool, despair and delight.

Director: Keith Osborn
 Producer: Ringling School of Art and Design
 Animation: Keith Osborn
 Faculty Advisor: Jim McCampbell
 Special Thanks: Debbie Osborn

Contact:
Keith Osborn
Ringling School of Art and Design
4074 32nd Avenue North
St. Petersburg, FL 33713
USA
+1.727.528.6402
+1.941.359.7669 fax
keithrsad@yahoo.com
www.rsad.edu

02 Plumber

6:28

Mario is determined to fix his leaky tap. All shots of Mario involve dynamically-simulated clothing, and every frame has been rendered with a mix of traditional/advanced lighting techniques and global photon mapping.

Directors: Andy Knight,
 Richard Rosenman
 Producer: Randi Yaffa
 Contributors: Red Rover Studios Ltd., Bravo!, Foundation to Assist Canadian Talent (FACT), NewArtsChannel
 3D Artists: Ben Pilgrim,
 Chris Crozier, Kyle Dunlevy,
 Mike Oliver, Raine Anderson

Contact:
Randi Yaffa
Red Rover Studios Ltd.
345 Adeliade Street West
Suite 5
Toronto, Ontario M5V 1R5
Canada
+1.416.591.6500
+1.416.591.6501 fax
randi@redrover.net
www.redrover.net

03 Shining Lore

2:39

A legend of eight heroes that connect the Age of Legend and the Age of Water. It has been several hundred years since the ocean disappeared and the world is slowly becoming a desert. In this scene Rune and three young heroes are protecting the secret they have discovered that will bring the waters again. Originally released as an online game and now slated for a Korean television series.

Director/Producer: B.J. Park
Contributors: Owen Klatte, Igor Lodiero, Ignacio Wilford, David Gurrea, Tae Wan Kim, Seung Hun Lee, Mike Kimmel, Ron Freidman, Chang Eui Im, Mihyun Park

Contact:
Owen Klatte
NCsoft Corp.
130 North Brand Boulevard
Suite 206
Glendale, CA 91203
USA
+1.818.553.1687
owen@pitchbluestudios.com

04 TicToc

2:53

Two naughty girls have a night out. They dance and have to cope with strange guys, and a handsome shark. Tic falls in love.

Director: Gunter Grossholz
Producer: Antje Krutz
Script: Gunter Grossholz
Camera: Martin Ference
Editing: Kilian
Animation: Gunter Grossholz, Heidi Wittlinger, Torben Meier

Contact:
Katrin Arndt
Institut of Animation, Visual
Effects and Digital
Postproduction
Filmakademie Baden-
Wuerttemberg
Mathildenstr. 20
71638 Ludwigsburg
Germany
+49.7141.969.800
+49.7141.969.888 fax
animationsinstitut@filmakade
mie.de
www.animationsinstitut.de

05 “Yeah! The Movie”

2:30

Ogre is our real-time rendition of Spellcraft Studio’s animation “Yeah! The Movie”. Using the vertex and fragment shaders, we were able to match their animation and shading, with time left over for adaptive subdivision and shadows! All so our friendly ogre could dance with his little friends before dinner.

Contributors: NVIDIA and Spellcraft Studio GmbH

Contact:

Joe Demers
NVIDIA and Spellcraft Studio
GmbH
2701 San Tomas Expressway
Santa Clara, CA 95050
USA
+1.408.486.2143
jdemers@nvidia.com

06 Cane-Toad

3:57

This animated short film is a toad’s perspective of the dangers involved in being a wanted species. Young Baz has gone missing and his good mate Dazza gives an insight into what may have happened to the little fella. Cane-Toad was made in a Brisbane “share house” by independent animators Dave Clayton and Andrew Silke.

Directors/Producers: Andrew Silke,
David Clayton
Compositing: Jeff Gaunt,
Naomi Anderlini
Sound: Angus Gibbons
Music: Gentlemen
Voice: Paul Davies
Script Assistance: James Cowen
Facilities: Cutting Edge Post

Contact:

Andrew Silke
Unit 9/5 Stanley Street
NSW 2031 Randwick
Australia
+61.2.9399.6740
andrewsilke@hotmail.com
www.cane-toad.com

07 Traffik

1:08

A man and his dog try to cross a busy intersection.

Director/Producer: Dave Bokser
Contributors: Michael Porten,
Cheryl Fell, Larry Lauria

Contact:
David Bokser
Savannah College of Art & Design
712 Avenue Y
Brooklyn, NY 11235
USA
+1.718.743.3524
dbokser@hotmail.com

08 WarCraft III: Reign of Chaos

18:14

This beautiful and evocative glimpse into the story of Warcraft is the best representation of the lands of Azeroth yet created. The Warcraft III Pre-Rendered Cinematics break new ground in computer graphics by bringing huge armies, cloak-enshrouded, long-haired characters, and photorealistic landscapes to the screen. Created on PC's running 3D Studio MAX. Compositing was handled using Adobe After Effects and Discreet Combustion.

Director: Nick Carpenter
Producer: Scott Abeyta
Contributors: Scott John Burnett,
John Chalfant, Jeff Chamberlain,
Aaron Chan, Ben Dai, Joe Frayne,
Jay Hathaway, Harley D. Huggins II,
Jared Keller, Jon Lanz, James McCoy,
Matthew Mead, Dennis Price,
Matt Samia, Mark Skelton,
Patrick Tho

Contact:
Scott Abeyta
Blizzard Entertainment
131 Theory
Irvine, CA
92612
USA
+1.949.955.1380 x1853
+1.949.737.2000 fax
sabeyta@blizzard.com

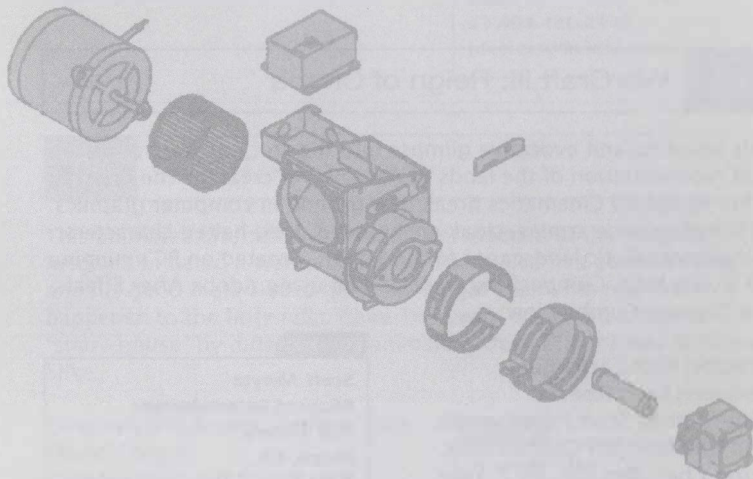

ACM Order#: NDVD145 ISBN#: 1-58113-718-4



Order Information:

SIGGRAPH Video Review
c/o ACM
PO BOX 11414
New York, NY 10286-1414
USA

phone: +1.800.342.6626 USA/Canada
+1.212.626.0500 International
fax: +1.212.944.1318
email: svrorders@siggraph.org
www.siggraph.org/publications/video-review/SVR.html



Dolby and the doubleD symbol are trademarks of Dolby Laboratories Licensing Corporation.



MANUFACTURED BY
TOSHIBA DIGITAL FRONTIERS INC.



Most of the pieces in this SIGGRAPH Video Review are copyrighted. Therefore, they are not to be duplicated, broadcast, photographed nor edited without the express written permission of the individual copyright holder