

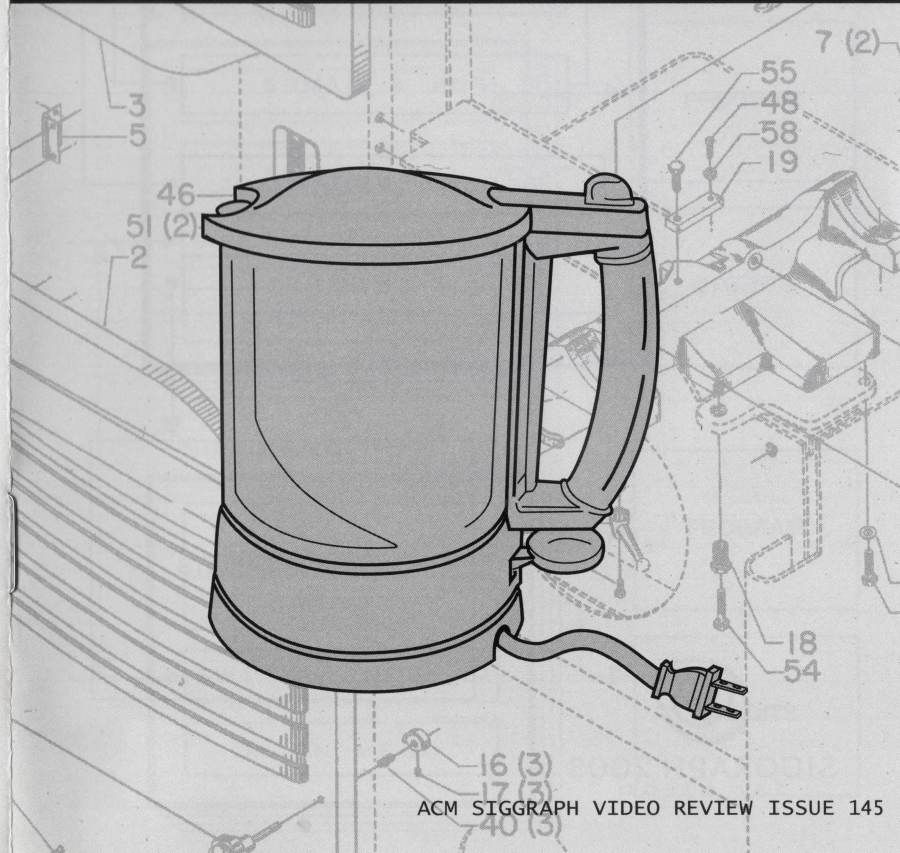

SIGGRAPH 2003  
SAN DIEGO

# ANIMATION THEATER PROGRAM PART 1

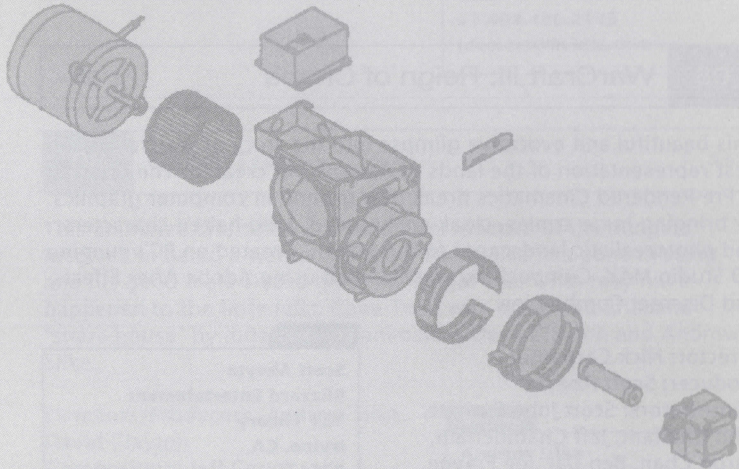

ACM Order#: NDVD145 ISBN#: 1-58113-718-4



**Order Information:**

SIGGRAPH Video Review  
c/o ACM  
PO BOX 11414  
New York, NY 10286-1414  
USA

phone: +1.800.342.6626 USA/Canada  
+1.212.626.0500 International  
fax: +1.212.944.1318  
email: svrorders@siggraph.org  
www.siggraph.org/publications/video-review/SVR.html



4:3



Dolby and the double-D symbol are trademarks  
of Dolby Laboratories Licensing Corporation.



MANUFACTURED BY  
TOSHIBA DIGITAL FRONTIERS INC.

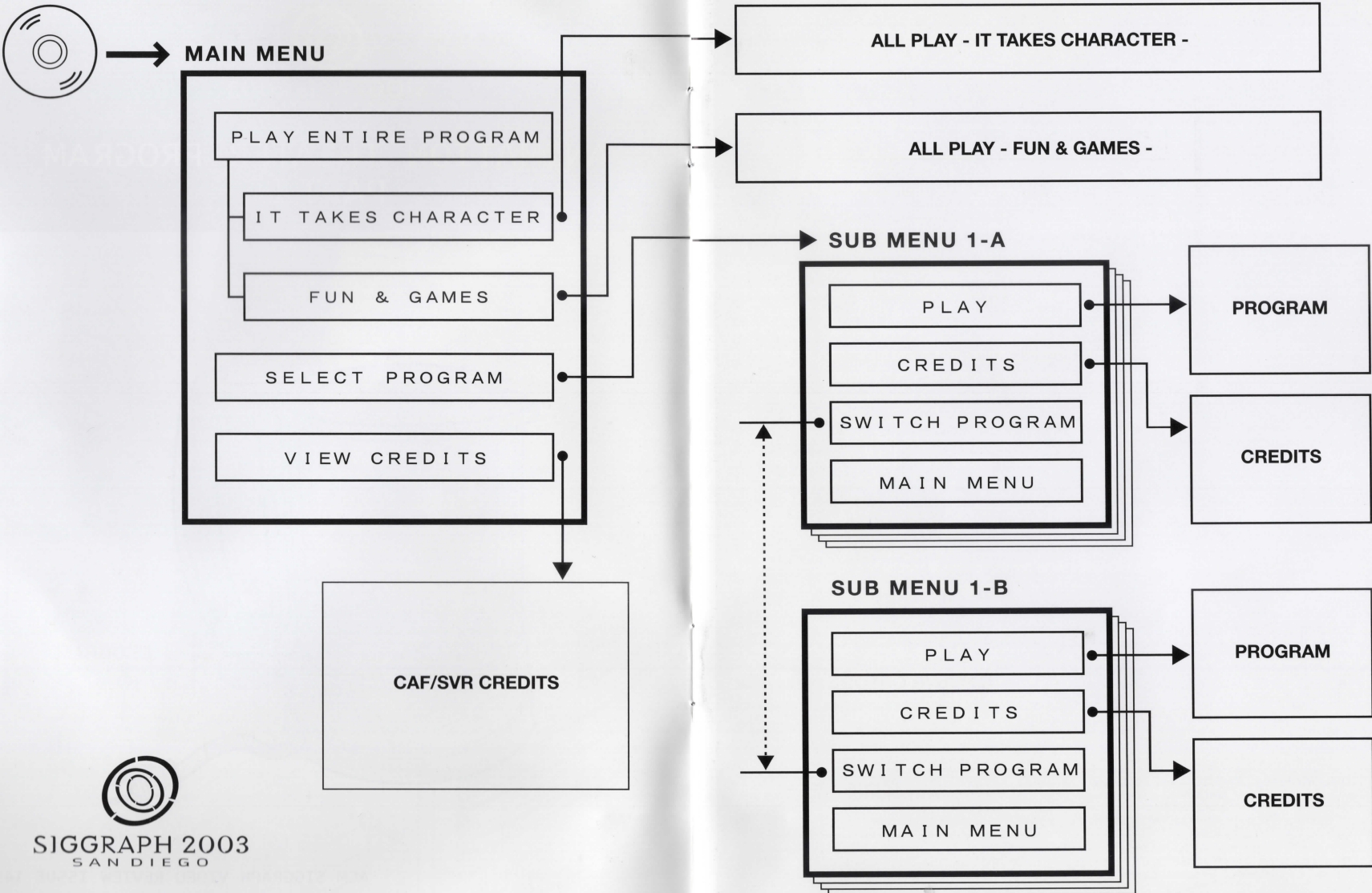

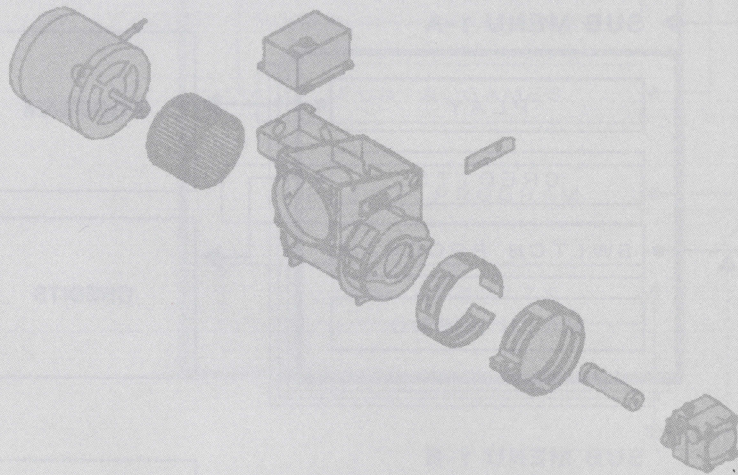

**Order Information:** SIGGRAPH Video Review phone: +1.800.342.6626 USA/Canada  
c/o ACM +1.212.626.0500 International  
PO BOX 11414 fax: +1.212.944.1318  
New York, NY 10286-1414 email: svrorders@siggraph.org  
USA www.siggraph.org/publications/video-review/SVR.html

Most of the pieces in this SIGGRAPH Video Review are copyrighted. Therefore, they are not to be duplicated, broadcast, photographed nor edited without the express written permission of the individual copyright holder.

#### IT TAKES CHARACTER

- 01 Carl & Ray Continued: Tippett Studio 3D Character Animation for Blockbuster - Tippett Studio
- 02 Bert - Academy of Art College
- 03 Sprite "Kebab" - Glassworks
- 04 Solder Man - Crash & Sues
- 05 Pingwin - Wojtek Wawszczyk
- 06 My Backyard - Vancouver Film School
- 07 Sam - Kyle Winkelman / Savannah College of Art & Design
- 08 El Arquero - Vancouver Film School
- 09 On the Sunny Side of the Street - The Soulstage Department
- 10 SpiderWeb - Rhythm & Hues Studios
- 11 Rittersschlag - Filmakademie Baden-Wuerttemberg
- 12 This Wonderful Life - Liam Kemp

#### FUN & GAMES

- 01 Baby Changing Station - Ringling School of Art and Design
- 02 Plumber - Red Rover Studios Ltd.
- 03 Shining Lore - NCsoft Corp.
- 04 TicToc - Filmakademie Baden-Wuerttemberg
- 05 "Yeah! The Movie" - NVIDIA and Spellcraft Studio GmbH
- 06 Cane-Toad - Andrew Silke
- 07 Traffik - Savannah College of Art & Design
- 08 WarCraft III: Reign of Chaos - Blizzard Entertainment

## IT TAKES CHARACTER

01

**Carl & Ray Continued:**

Tippett Studio 3D Character Animation for Blockbuster

| 1:10

The continuing adventures of "Carl & Ray", those zany, furry Blockbuster Video characters created by the artists of Tippett Studio. In this year's montage, the Tippett team has further refined and built on the artistic and technical challenges of bringing photo-real house pets into the realm of the fantastic. Whether they be dancing, sliding, juggling, or dripping with water, Carl & Ray continue to entertain audiences worldwide while setting new standards for photo realistic fur and 3D character animation.

Director: Steve "Spaz" Williams

Producers: Carol Corwin, Alonzo Ruvalcaba, Clint Goldman,  
Paul Renusch, Josh Reynolds

Visual Effects Supervisors: Joel Friesch, Jim McVay, Scott Souter,  
Frank Petzold

Producers: Carol Corwin, Alonzo Ruvalcaba

Lead Animators: Todd Labonte, Eric Reynolds

Animators: Jim Brown, Raquel Coelho, David House, Patrick Lowery,  
Karen Prell, Morgan Ratsoy

Puppet: Tracey Roberts

Model: John Koester

Paint: Laura Hainke, Raine Reene, John McLaughlin

Technical Directors: Kirsten

Drummond, Tulio Hernandez,

Holly Kim, Jim Valladao,

Ben Von Zastrow

Compositors: Charles Granich,

Keith McGowan, Chris Morely,

Ben Von Zastrow

VFX Coordinator: Dan Riha

VFX Editors: John Bartle,

Jennifer Hutcheon

Software Development:

Todd Stinson

**Contact:**

**Jim Bloom**  
Tippett Studio  
2741 10th Street  
Berkeley, CA 94710  
USA  
+1.510.649.9711  
+1.510.649.9788 fax  
jbloom@tippett.com  
www.tippett.com

02

**Bert**

| 4:30

A tale of a young vegetable's search for family. "Bert" is Lee's first film and senior project at Academy of Art College, San Francisco.

Director/Producer: Moonsung Lee

Contributors: Trio Voronezh,  
Jed Diffenderfer, Jimmy Hayward,  
Oren Jacob, Dave Burgess,  
Andrew Leung, Hyunjoo Jung

**Contact:**

**Moonsung Lee**  
Academy of Art College  
25 Rockledge Avenue #912  
White Plains, NY 10601  
USA  
+1.914.948.7932  
spiff73@hotmail.com  
artist.cgland.com/spiff73

03

**Sprite "Kebab"**

| 00:30

A goblin in a kebab shop is brimming with innocent yet mischievous character. The facial expressions and delicate arm and finger movements bring the 'sprite' to life. The goblin was originally sculpted by hand and then made into a full latex puppet. The puppet was then laser scanned to provide 3D wireframes, Glassworks then applied high-resolution digital images of the original puppet to the wireframes to create the 3D model and give it texture.

Director: Kuntz / Maguire

Producer: Zoe Rogers

**Contact:**

**Jay Lichtman**  
Glassworks  
33/34 Great Pulteney Street  
W1F 9NP London  
United Kingdom  
+44.207.4343.1182  
jay@glassworks.co.uk

## 04 Solder Man

3:53

A story of creation, evolution and problem solving. After experiencing a problem with his creation, solder man looks to solve his dilemma the only way that he knows how, by soldering. With great effort he is successful, but finds himself in much worse shape. Then as luck or fate would have it, he stumbles across a substance that greatly expands his horizons. Life though is never without its problems, and in the end we are left wondering how much he has grown.

**Contact:**

**Dave Novak**  
**Crash & Sues**  
**510 Marquette Avenue**  
**Suite 600**  
**Minneapolis, MN 55402**  
**USA**  
**+1.612.338.7947**  
**+1.612.338.4601 fax**  
**dave@crash-sues.com**

Director/Producer: Dave Novak  
 CG: Dave Novak  
 Compositing: Jake Parker  
 Color Correction: Sue Lakso,  
 Demetri Kitsopoulos  
 Sound: Echo Boys  
 Effects: Tom Lecher  
 Music: Alex Berglund, Billy Franklin

## 05 Pingwin

2:40

A short animated movie about a penguin who wants to fly.

**Contact:**

**Wojtek Wawszczyk**  
**Radomska 14/62**  
**41-219 Sosnowiec**  
**Poland**  
**+48.6.0695.0987**  
**wawszczyk@yahoo.com**

Director: Wojtek Wawszczyk  
 Producers: Wojtek Wawszczyk,  
 Georg Gruber  
 Contributors: Kamil Polak,  
 Alan Shamsudin

## 06 My Backyard

1:03

A spider's journey.

**Contact:**

**Sabrina de los Rios**  
**Vancouver Film School**  
**420 Homer Street**  
**Vancouver, BC V6B 2V5**  
**Canada**  
**+1.604.685.6331 x109**  
**+1.604.685.6317 fax**  
**sabrina@vfs.com**  
**www.vfs.com**

Director: Chrisoph Ammann  
 Producer: Vancouver Film School

## 07 Sam

5:29

In the distant future of a galaxy very dissimilar to our own, an otherworldly janitor named Sam begins his duties at the cargo distribution center of WGA-Minora Biocybernetics. In the midst of cleaning up debris and longing for a life other than his own, Sam is suddenly presented with an unsupervised cargo plane, a disk containing all the knowledge of a cargo pilot, and the opportunity for the misadventure of a lifetime.

**Contact:**

**Kyle Winkelman**  
**Savannah College of Art & Design**  
**318 West Hall Street**  
**Apartment B**  
**Savannah, GA 31401**  
**USA**  
**+1.912.713.1541**  
**superwinkel@hotmail.com**

Director: Kyle Winkelman  
 Producer: Joe Pasquale  
 Animation: Joshua Merck  
 Lighting: Ginka Kostova  
 Sound Design: Robin Beauchamp

## 08 El Arquero

4:41

An archer's wild shot leads to a frantic chase with the constellation Leo.

**Contact:**

**Sabrina de los Rios**  
**Vancouver Film School**  
**420 Homer Street**  
**Vancouver, BC V6B 2V5**  
**Canada**  
**+1.604.685.6331 x109**  
**+1.604.685.6317 fax**  
**sabrina@vfs.com**  
**www.vfs.com**

Director: Raphael Perkins  
 Producer: Vancouver Film School

**09** On the Sunny Side of the Street

4:58

A Harlem street scene in the 1920's. H.H. Sablin just wants to read his daily newspaper, as his bench-neighbor Pit Doogey acts very busy preparing a barbeque, without taking any regard of Sablin. Under these conditions, the accidental meeting of both couldn't have a happy ending, could it?

Directors: Wilhelm Landt,  
Joachim Bub  
Producer: The Soulcase Department  
Contributors: Wilhelm Landt,  
Joachim Bub, Elmar Keweloh,  
Mike Meyer

**Contact:**

**Wilhelm Landt**  
**The Soulcase Department**  
**Mecklenburgerstrasse 10**  
**28203 Bremen**  
**Germany**  
**+49.421.794.7020**  
**willi@soulcase-department.de**

**10** SpiderWeb

1:00

For Rhythm & Hues, an animation house utilizing both proprietary and commercial software packages, the ability to freely exchange useful data between applications is essential. The options become quite liberating in a modular pipeline.

Director: Sei Nakashima  
Producer: Stacy Burstin  
Animation Director:  
Christopher Romano  
Producer: Stacy Burstin  
Music Composer: Steve Kutay  
Sound Designer: Michael Miller  
Sound Effects Editors:  
Michael D'Ambrosio, Tim DeLone

**Contact:**

**Stacy Burstin**  
**Rhythm & Hues Studios**  
**5404 Jandy Place**  
**Los Angeles, CA 90066**  
**USA**  
**+1.310.448.7500**  
**stacy@rhythm.com**  
**www.rhythm.com**

**11** Ritterschlag

7:00

Held in prison by dragons, the beautiful princess cries. This full CG short film was made by a small team in 13 months.

Director: Sven Martin  
Producer: Daniel Mann, Marco Gilles  
Animation: Sven Martin,  
Sebastian Frey  
Digital Environment:  
Sven Dreesbach, Volker Willmann  
Lighting: Oliver Finkelde  
Script: Marcus Sauermann  
Music: Marius Lange

**Contact:**

**Katrin Arndt**  
**Institut of Animation, Visual**  
**Effects and Digital**  
**Postproduction**  
**Filmakademie Baden-**  
**Wuerttemberg**  
**Mathildenstr. 20**  
**71638 Ludwigsburg**  
**Germany**  
**+49.7141.969.800**  
**+49.7141.969.888 fax**  
**animationsinstitut@filmakade**  
**mie.de**  
**www.animationsinstitut.de**

**12** This Wonderful Life

2:00

A young woman mourning the death of her husband takes a walk into the countryside, feeling alone and withdrawn from life. Her sense of isolation is lifted when she discovers, beneath a bridge, an abandoned baby. As the woman and the baby begin to develop a natural bond, her perception of what it means to be alive changes forever.

**Contact:**

**Liam Kemp**  
**66 Spindletree Drive**  
**Oakwood**  
**DE21 2DG Derby**  
**United Kingdom**  
**+44.133.283.2251**  
**liam@fourbarns.fsnet.co.uk**

## FUN &amp; GAMES

## 01 Baby Changing Station

1:22

Seeking a moment's peace in a mall bathroom, an exasperated father places his screaming, dirty-diapered child on a baby changing station and tries to regain his composure. The baby's screams seem to grow louder and show no sign of stopping. And then, silence.

He's afraid to look, but when he does, transformation of his attitude is not the only change that occurs in this tale of diapers and drool, despair and delight.

Director: Keith Osborn  
Producer: Ringling School of Art and Design

Animation: Keith Osborn  
Faculty Advisor: Jim McCampbell  
Special Thanks: Debbie Osborn

**Contact:**

**Keith Osborn**  
Ringling School of Art and Design  
4074 32nd Avenue North  
St. Petersburg, FL 33713  
USA  
+1.727.528.6402  
+1.941.359.7669 fax  
keithrsad@yahoo.com  
www.rsad.edu

## 02 Plumber

6:28

Mario is determined to fix his leaky tap. All shots of Mario involve dynamically-simulated clothing, and every frame has been rendered with a mix of traditional/advanced lighting techniques and global photon mapping.

Directors: Andy Knight,  
Richard Rosenman  
Producer: Randi Yaffa  
Contributors: Red Rover Studios  
Ltd., Bravo!, Foundation to Assist  
Canadian Talent (FACT),  
NewArtsChannel  
3D Artists: Ben Pilgrim,  
Chris Crozier, Kyle Dunlevy,  
Mike Oliver, Raine Anderson

**Contact:**

**Randi Yaffa**  
Red Rover Studios Ltd.  
345 Adeliade Street West  
Suite 5  
Toronto, Ontario M5V 1R5  
Canada  
+1.416.591.6500  
+1.416.591.6501 fax  
randi@redrover.net  
www.redrover.net

## 03 Shining Lore

2:39

A legend of eight heroes that connect the Age of Legend and the Age of Water. It has been several hundred years since the ocean disappeared and the world is slowly becoming a desert. In this scene Rune and three young heroes are protecting the secret they have discovered that will bring the waters again. Originally released as an online game and now slated for a Korean television series.

Director/Producer: B.J. Park  
Contributors: Owen Klatte,  
Igor Lodiero, Ignacio Wilford,  
David Gurrea, Tae Wan Kim,  
Seung Hun Lee, Mike Kimmel,  
Ron Freidman, Chang Eui Im,  
Mihyun Park

**Contact:**

**Owen Klatte**  
NCsoft Corp.  
130 North Brand Boulevard  
Suite 206  
Glendale, CA 91203  
USA  
+1.818.553.1687  
owen@pitchbluestudios.com

## 04 TicToc

2:53

Two naughty girls have a night out. They dance and have to cope with strange guys, and a handsome shark. Tic falls in love.

Director: Gunter Grossholz  
Producer: Antje Krutz  
Script: Gunter Grossholz  
Camera: Martin Ferenc  
Editing: Kilian  
Animation: Gunter Grossholz,  
Heidi Wittlinger, Torben Meier

**Contact:**

**Katrin Arndt**  
Institut of Animation, Visual  
Effects and Digital  
Postproduction  
Filmakademie Baden-  
Wuerttemberg  
Mathildenstr. 20  
71638 Ludwigsburg  
Germany  
+49.7141.969.800  
+49.7141.969.888 fax  
animationsinstitut@filmakade  
mie.de  
www.animationsinstitut.de

## 05 "Yeah! The Movie"

2:30

Ogre is our real-time rendition of Spellcraft Studio's animation "Yeah! The Movie". Using the vertex and fragment shaders, we were able to match their animation and shading, with time left over for adaptive subdivision and shadows! All so our friendly ogre could dance with his little friends before dinner.

Contributors: NVIDIA and Spellcraft Studio GmbH

**Contact:**

**Joe Demers**  
**NVIDIA and Spellcraft Studio GmbH**  
**2701 San Tomas Expressway**  
**Santa Clara, CA 95050**  
**USA**  
**+1.408.486.2143**  
**jdemers@nvidia.com**

## 06 Cane-Toad

3:57

This animated short film is a toad's perspective of the dangers involved in being a wanted species. Young Baz has gone missing and his good mate Dazza gives an insight into what may have happened to the little fella. Cane-Toad was made in a Brisbane "share house" by independent animators Dave Clayton and Andrew Silke.

Directors/Producers: Andrew Silke, David Clayton  
 Compositing: Jeff Gaunt, Naomi Anderlini  
 Sound: Angus Gibbons  
 Music: Gentlemen  
 Voice: Paul Davies  
 Script Assistance: James Cowen  
 Facilities: Cutting Edge Post

**Contact:**

**Andrew Silke**  
**Unit 9/5 Stanley Street**  
**NSW 2031 Randwick**  
**Australia**  
**+61.2.9399.6740**  
**andrewsilke@hotmail.com**  
**www.cane-toad.com**

## 07 Traffik

1:08

A man and his dog try to cross a busy intersection.

Director/Producer: Dave Bokser  
 Contributors: Michael Porten, Cheryl Fell, Larry Lauria

**Contact:**

**David Bokser**  
**Savannah College of Art & Design**  
**712 Avenue Y**  
**Brooklyn, NY 11235**  
**USA**  
**+1.718.743.3524**  
**dbokser@hotmail.com**

## 08 WarCraft III: Reign of Chaos

18:14

This beautiful and evocative glimpse into the story of Warcraft is the best representation of the lands of Azeroth yet created. The Warcraft III Pre-Rendered Cinematics break new ground in computer graphics by bringing huge armies, cloak-enshrouded, long-haired characters, and photorealistic landscapes to the screen. Created on PC's running 3D Studio MAX. Compositing was handled using Adobe After Effects and Discreet Combustion.

Director: Nick Carpenter  
 Producer: Scott Abeyta  
 Contributors: Scott John Burnett, John Chalfant, Jeff Chamberlain, Aaron Chan, Ben Dai, Joe Frayne, Jay Hathaway, Harley D. Huggins II, Jared Keller, Jon Lanz, James McCoy, Matthew Mead, Dennis Price, Matt Samia, Mark Skelton, Patrick Tho

**Contact:**

**Scott Abeyta**  
**Blizzard Entertainment**  
**131 Theory**  
**Irvine, CA**  
**92612**  
**USA**  
**+1.949.955.1380 x1853**  
**+1.949.737.2000 fax**  
**sabeyta@blizzard.com**